

ISUZU
TRAGA
BLIND VAN

EXTRA UNTUNGNYA LEGA MUATANNYA



REAL PARTNER. REAL JOURNEY.



MESIN HANDAL DAN IRIT

Isuzu Traga Blind Van menggunakan mesin diesel 4JA1-L berkapasitas 2.500cc yang terbukti bertenaga besar, handal dan irit bahan bakar sehingga lebih menguntungkan.



VOLUME CARGO TERLUAS DI KELASNYA

Isuzu Traga Blind Van dirancang dengan volume cargo yang luas dengan ukuran panjang 2,9 m, lebar 1,5 m dan Tinggi 1,2 m atau setara dengan volume 5,22 m³ yang merupakan cargo terluas di kelasnya mampu mengangkut lebih banyak sehingga lebih menguntungkan dan menghemat biaya operasional proses pengantaran.

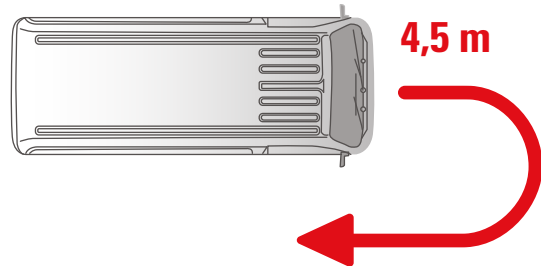

KUALITAS LEBIH BAIK

Isuzu Traga Blind Van hadir dengan cargo belakang berkualitas standard pabrik dengan volume cargo yang luas, solusi kendaraan niaga untuk bisnis kurir di area perkotaan sehingga distribusi barang menjadi lebih cepat dan mudah.

MUDAH BERMANUEVER

Lalu lintas yang tidak menentu menjadikan kemudahan bermanuever menjadi salah satu poin penting dalam memilih armada bisnis Anda. Isuzu Traga Blind Van didukung transmisi 5 percepatan dan memiliki radius putar minimal 4,5 m, sehingga mudah bermanuever.

TAMPAK SAMPING KANAN

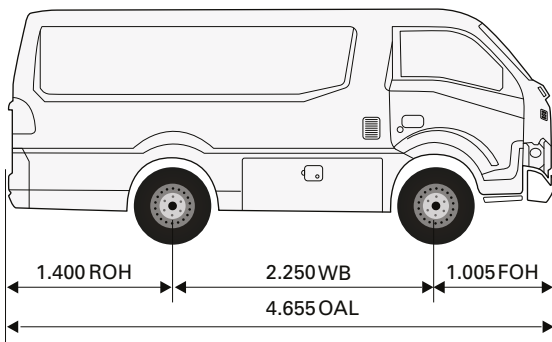

TAMPAK SAMPING KIRI

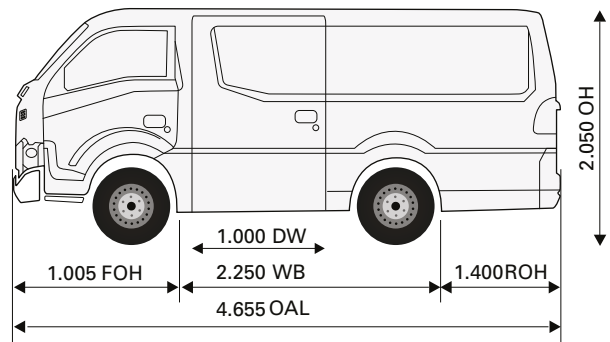

TAMPAK ATAS

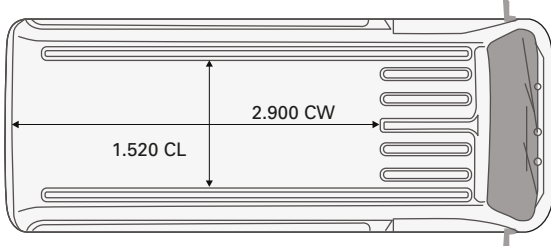

TAMPAK BELAKANG

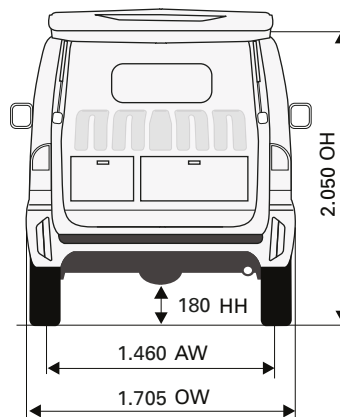

TAMPAK DEPAN

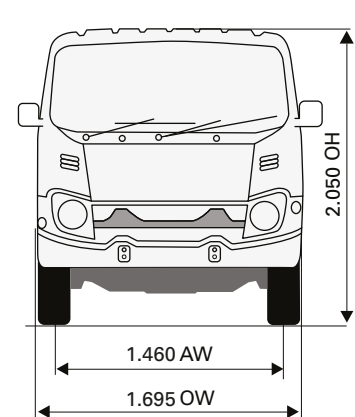

*Dimensi dalam satuan Milimeter (mm)

SPESIFIKASI TEKNIS

ISUZU TRAGA BLIND VAN

DIMENSI / DIMENSION

Panjang / Overall Length (OAL)	mm	4,655
Lebar / Overall Width (OW)	mm	1,695
Tinggi / Overall Height Front (OH)	mm	2,050
Jarak Sumbu / Wheelbase (WB)	mm	2,250
Jejak Depan / Front Tread (AW)	mm	1,460
Jejak Belakang / Rear Tread (CW)	mm	1,460
Julur Depan / Front Overhang (FOH)	mm	1,005
Julur Belakang / Rear Overhang (ROH)	mm	1,400
Lebar Cargo / Cargo Width (CW)	mm	1,520
Panjang Cargo / Cargo Length (CL) Top	mm	2,900
Tinggi Cargo / Cargo Height Inner (CL)	mm	1,200
Jarak Terendah ke Tanah / Ground Clearance (HH)	mm	180
Lebar Pintu / Door Width (DW)	mm	1,000

MESIN / ENGINE

Model		4JA1L
Tipe / Type		4 Cylinder, Direct Injection with Turbocharger
Diameter x Langkah / Bore x Stroke	mm	93 x 92
Isi Silinder / Piston Displacement	cc	2,499
Tenaga Maksimum / Maximum Power	PS / rpm	80 / 3,500
Torsi Maksimum / Maximum Torque	Kgm / rpm	19.5 / 1,800

BERAT / WEIGHT

Berat Brutto / Gross Vehicle Weight (GVW)	kg	2,950
---	----	-------

REM / BRAKE

Kontrol Rem / Brake Control		Hydraulic Dual Circuit
Depan / Front		Ventilated Disc
Belakang / Rear		Drum, leading & trailing

SISTEM KEMUDI / STEERING SYSTEM

Tipe / Type		Rack and pinion
Power Steering		Yes
Radius Putar / Turning Radius	m	4,5

TRANSMISI / TRANSMISSION

Model		MUA5S
Sistem / System		Manual (M/T) - 5 Speed
Perbandingan Gigi / Gear Ratio	1st	4.357
	2nd	2.502
	3th	1.501
	4th	1.000
	5th	0.809
	Rev	3.970
Perbandingan Gigi Akhir / Final Gear Ratio		4.777

BAN / TYRE

Velg / Wheel		6 Stud 14 x 5.5
Ban Depan / Front Tyre (Type)		195R14-8PR
Ban Belakang / Rear Tire (Type)		195R14-8PR

SUSPENSI / SUSPENSION

Depan / Front		Double wishbone with coil spring
Belakang / Rear		Leaf spring type

LAIN-LAIN / OTHERS

Pintu Belakang / Hatchback		1
Pintu Samping / Swing Door		1
Kapasitas Tangki / Fuel Tank Capacity	liter	50
Alternator	V-A	12 - 60
Aki / Accu	V-AH	12 - 65
Fan Blower		Yes
Head Unit		Yes